



SPIGOT RAILING INSTALLATION INSTRUCTIONS

Invisirail.com • 1-905-852-3733 • Toll Free: 1-888-681-9733 • sales@invisirail.com



PRE-INSTALLATION

- Consult with professionals and local building officials before starting installation to confirm building code compliance in your area. The consumer and/or installer are responsible for confirming any installed products will satisfy local building code requirements.
- The consumer and/or installer should take all necessary steps to ensure the safety of all involved in installation including the use of PPE such as safety glasses, work gloves, etc.
- Minimum two (2) people are necessary to handle and install glass panels
- For wood-framed decks, there must be proper blocking in between joists to secure spigots.

TOOLS / SUPPLIES REQUIRED

- Power drill
- T-40 bit for wood fasteners
- Bubble level
- Tape measure
- Pencil/pen/marker
- Metric hex keys for spigot set screws
- String line / chalk line
- Pipe cutter or saw with carbide-tipped metal cutting blade if installing stainless steel handrail or top rail.
- ½” drill bit (for double gate installation only)

ADDITIONAL TOOLS / SUPPLIES REQUIRED FOR CUSTOM STAIR GLASS TEMPLATING:

- Box cutter/knife to cut cardboard OR saw to cut hardboard/plywood
- A long straight edge i.e., drywall square OR string line
- Clamps to hold template material in spigots (optional)
- Drill bit to drill holes in template for through-bolt (3/8” minimum) [optional]
- Household glass cleaner or soap and water for cleaning glass after installation is complete.

RECEIVING YOUR ORDER

- You must inspect your shipment for evidence of damage before accepting delivery. If evidence of damage is found please notify the shipper immediately.
- Your provided layout drawing shows where each size glass panel will be located and what gaps you should have in between panels.
- The Spigot Spacing Chart (on page 12) shows how far apart spigots should be for various glass widths.
- Corner Detail Drawings (on page 11) will show how to position corner panels to maintain spacing.
- These documents and others can be found on our website (Invisirail.com) or by contacting Invisirail:
PHONE: 905-852-3733
TOLL FREE: 1-888-681-9733
EMAIL: sales@invisirail.com
- It is recommended to install one glass panel at a time instead of installing all spigots 1st and all glass 2nd.
- When you receive your crate, you'll notice that the glass panels have been piled from largest to smallest (with the smallest sizes on top). To reduce the number of times panels need to be moved, it is recommended that the smallest panels are installed first. When removing panels from crate take care to lift each panel clear of the one below and do not drag any edges.

POSITIONING SPIGOTS / BLOCKING

See below example. The Corner Detail Drawing(s), Spigot Spacing Chart, and Layout Drawing should be used to determine where the spigots will be located (and where blocking needs to be located).

Use a string line or mark a chalk line 2 5/8" in from outer edge of rim joists to indicate centre line of glass. Mark the centre line 4" in from edge for concrete installations. Install one glass panel at a time instead of installing all spigots 1st and all glass 2nd.

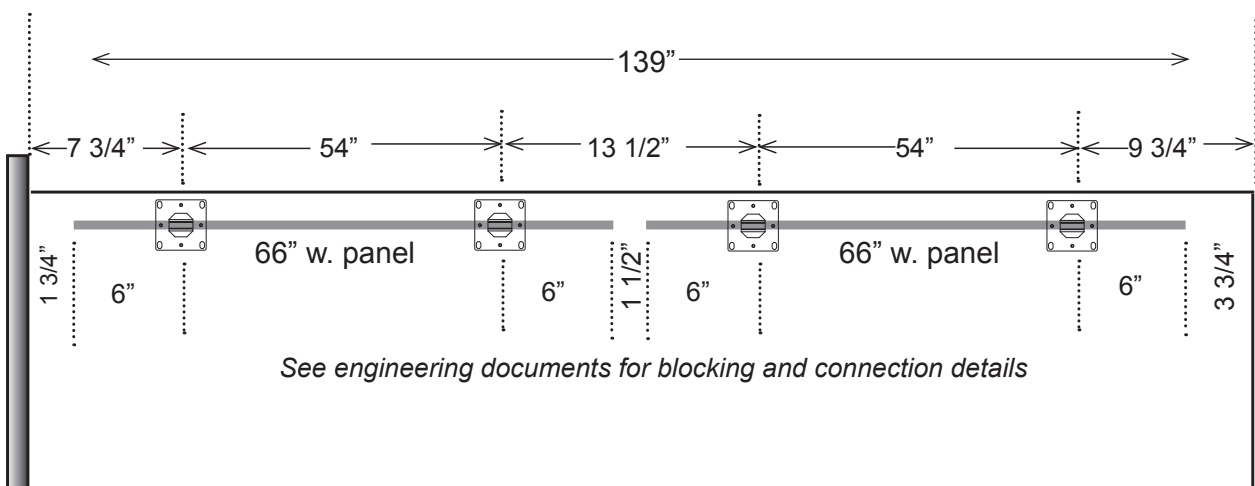

INSTALLING SPIGOTS & GLASS

The 7.5" spigots include several different types of set screws that will allow you to make adjustments to ensure the glass is sitting level and plumb:

- Spigot flange base set screws (x4)
- Glass height set screw (x1)
- Glass tilt set screws (x4)

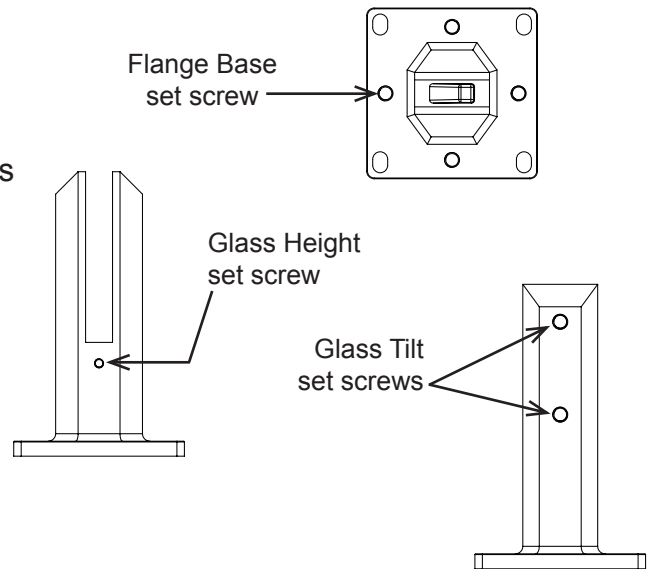

1. Using your Layout Drawing and Spigot Spacing Chart for spacing reference, centre two spigots for one panel on your string / chalk line. Ensure each spigot includes the flat plate underneath.
2. Use the Flange Base Set Screws and small level to ensure individual spigots are plumb in both directions. For extremely uneven surfaces (i.e., armour stone) you may require additional shims to ensure spigots are plumb. Use provided fasteners to secure spigots to surface.
3. Slide glass panel into spigots. Re-check that spigots are still plumb. Further adjustment can be done by tightening fasteners and / or using the Flange Base Set Screws.
4. Additional black plastic gaskets have been included with each spigot. Insert as required in the spigot to fill the openings.
5. Install the next glass panel following steps 1-4. Refer to your Layout Drawing for spacing in between panels.
6. After all glass panels are installed, you'll need to ensure the top edges of all panels line up with each other and are level. Each spigot includes a small Glass Height Set Screw to raise the height of the glass by as much as $\frac{1}{4}$ ".
7. Lastly, use the Glass Tilt Set Screws to ensure panels are plumb and secured in the spigots.
8. After all adjustments have been made and the glass panels are secure in the spigots, install the two-piece skirt onto the spigot bases.

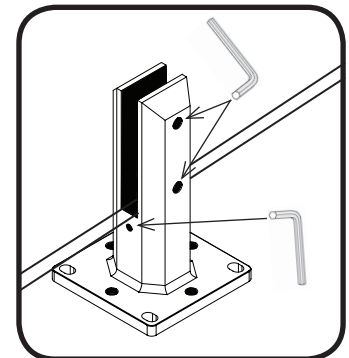
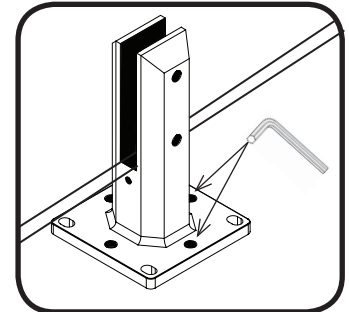

9. If your order includes stair glass, glass gate(s), glass-to-glass clamps or continuous top rail see below. Otherwise, skip to Step 10.

- Templating for Stair Glass see page 6.
- Glass Gates see page 7.
- Glass-to-Glass Clamps:
 - Loosen the center bolt than holds the clamp together.
 - Slide clamp in between glass panels and tighten center bolt.
 - Tighten small set screws in clamps to tighten onto the glass panels.
- Continuous Top Rail:
 - Insert rubber gaskets into rail.
 - Slide lengths of top rail onto glass.
 - Use fittings (joiners, 90deg corners, etc) to join lengths of top rail.

10. After installation is complete, peel all stickers and corks off of glass and clean with mild soap and water or household glass cleaner.



STAIR TEMPLATING INSTRUCTIONS

- Cardboard is typically provided with orders to use for templating. Alternatively, you can use hardboard, plywood or similar material.
- Ideally you will want to make the top edge of your stair glass line up with the rest of your railing. There are several different ways to cut the template for the bottom edge(s) of the glass:

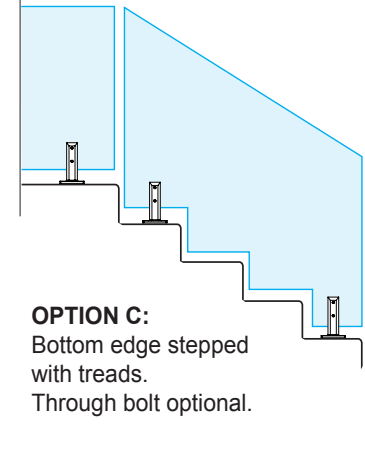
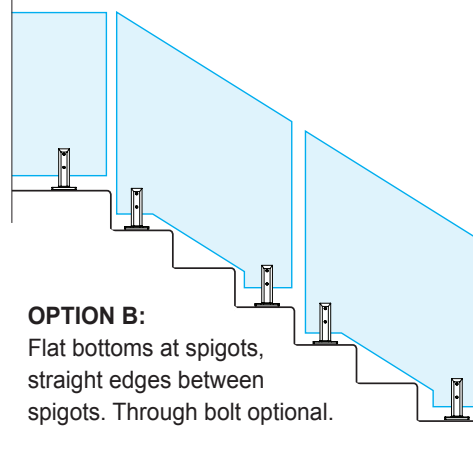
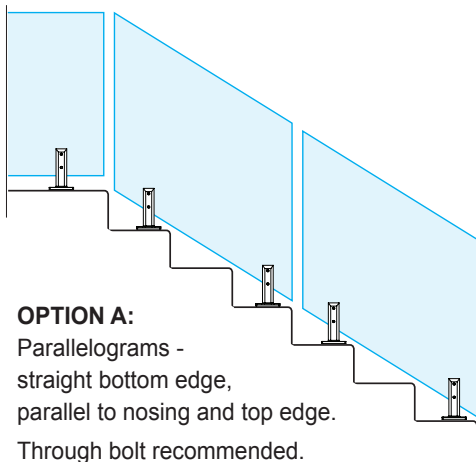

- Stair glass panels should not exceed 72" long diagonally.
- The length of your stair and number of treads will determine how to lay-out the spigots down the staircase.
- Position the spigots as close to the stair nosing as possible to allow the glass to easily clear the nosing of the stairs.
- You can either screw down your spigots as you're templating, or wait until you receive the glass before screwing down the spigots.
- The bottom edge of the templates/glass should be tight enough to the treads that a 6" diameter ball cannot pass through underneath the template.

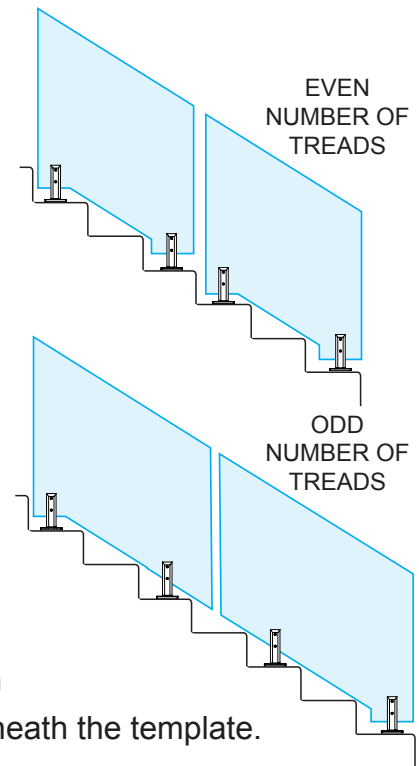

- If your stair glass will feature glass-mounted handrail, please note on the templates where the handrail should be located or where the holes for the glass-mounted handrail brackets should be drilled.

- Custom stair glass panels will be made to the exact specifications of the template(s). Sharp corners (less than 90 degrees) are typically made with a ½” radius for safety.
- Please ensure that templates are not damaged, warped etc. before being sent to Invisirail. Try to minimize the number of bends/folds in the template material if possible.
- If there are any problems with the templates or if any info is missing, Invisirail will contact you to resolve. In extreme cases Invisirail may request for new template(s) to be made and sent.
- Please write the following info on the template(s):
 - Name of store where the order was purchased
 - Sales order number / purchase order number / original estimate number
 - Date templates were made
 - Contact info for installer who made the templates (name, phone number, email)
 - Panel identification (i.e. upper, lower, 1 of 2, 2 of 2, etc.)

Please send templates to: **Invisirail,**
6050 Owen Road, Unit #1,
Uxbridge, ON L9P-1R1
Canada

Customers outside of Canada will need to fill out a commercial invoice to ship across the border. If you need assistance, please email sales@livbp.com or call toll-free 1-888-681-9733. After the glass is manufactured, Invisirail will confirm that its shape and size matches the provided template and will ship both to the customer.

SPIGOT GLASS GATE INSTALLATION

- 1) Install fixed hinge panel in spigots. Note that the spigot further away from the hinges will require a through-bolt to help keep the glass in place. Ensure that the panel is installed with edges plumb/level.
- 2) Install hinges onto fixed hinged panel, ensure they are oriented correctly and the hydraulic hinge is located on the bottom and the spring-loaded hinge on top.
- 3) Install the operating gate panel onto hinges. Confirm that both the operating gate panel and fixed hinged panel are both still plumb/level.

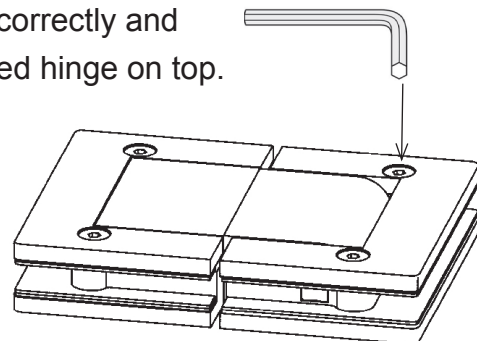

SINGLE GATE

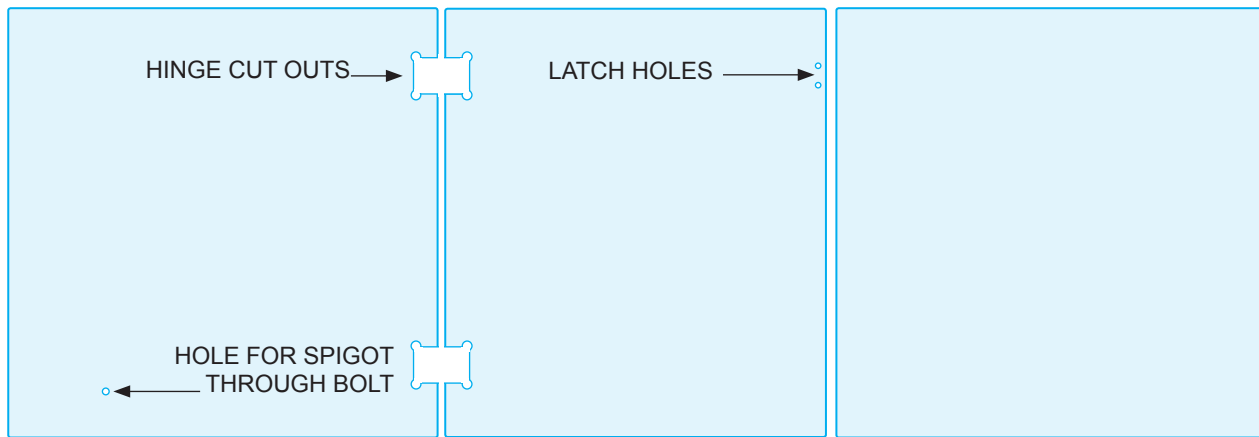
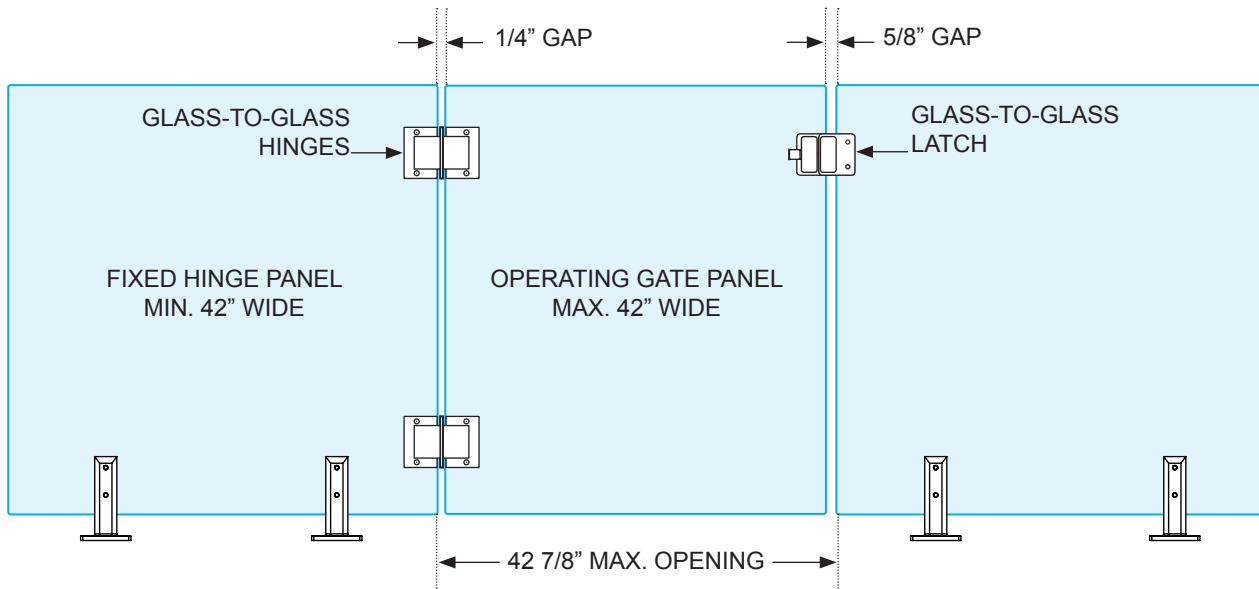

FOR SINGLE GLASS GATES:

- Install the pull-pin latch onto the operating gate panel using the two small bolts to fasten the assembly through the two 3/8" holes in the glass.
- Install the next fixed glass panel. This panel will not include any holes in the glass.
- Install the magnetic, glass-mounted latch receiver onto the fixed panel of glass such that it lines up with the pull-pin latch. This half of the latch is secured on the glass by small set screws. Ensure the foam side of the loose metal plate is against the glass before tightening the set screws.
- Once all gate components are installed, adjust the hinge closing speed by turning the valve control screws located on the hinge. See page 10.
- Make small incremental turns to the screws to adjust the closing speed. Ensure the latch gently closes without slamming. Test several times to ensure successful operation.

DOUBLE GATE

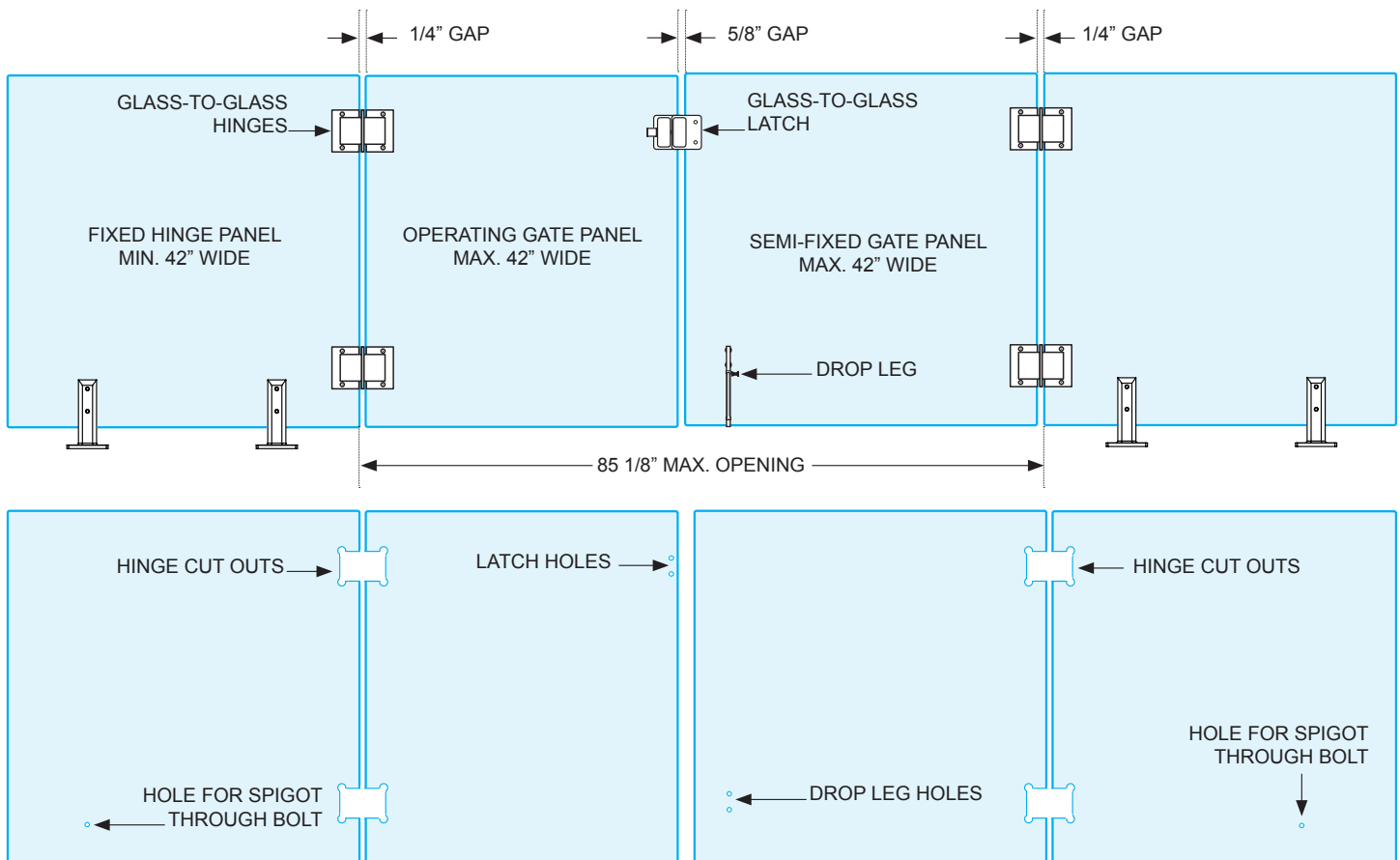

FOR DOUBLE GLASS GATES:

- Install the semi-fixed glass panel using steps 1-3 .
- Install the pull-pin latch onto the operating gate panel using the two small bolts to fasten the assembly through the two 3/8" holes in the glass.
- Install the magnetic, glass-mounted latch receiver onto the semi-fixed gate panel. This half of the latch is secured on the glass by small set screws. Ensure the foam side of the loose metal plate is against the glass before tightening the set screws.
- Install the dropleg bolt onto the semi-fixed glass panel.
- Once both gate panels are installed, ensure they line up with each other and mark the position of the dropleg bolt on the deck surface. Drill a 1/2" hole in the deck surface.
- Once all gate components are installed, adjust the hinge closing speed by turning the valve control screws located on the hinge. See page 10.
- Make small incremental turns to the screws to adjust the closing speed. Ensure the latch gently closes without slamming. Test several times to ensure successful operation.

Speed adjustment:

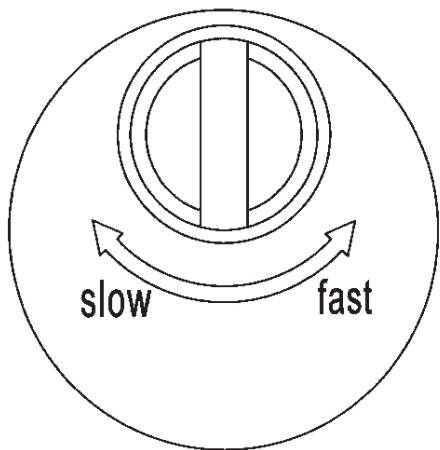

Hydraulic hinge

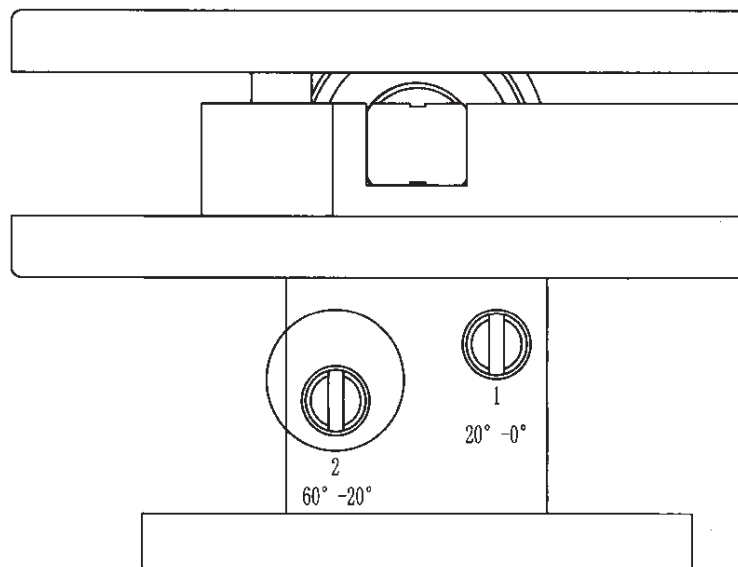

1. Fully tighten the No1 and No2 speed adjusting valves
2. Loose the No1 and No2 valves by 1/4 turn .
3. Adjust the No2 valve to ideal closing speed
4. Adjust the No1 valve to ideal closing speed
5. It's suggested to turn no more than 1/4 turn each time you adjust the valves.

WARNING: Fully unscrewing the speed adjustment screw will damage the hydraulic function.

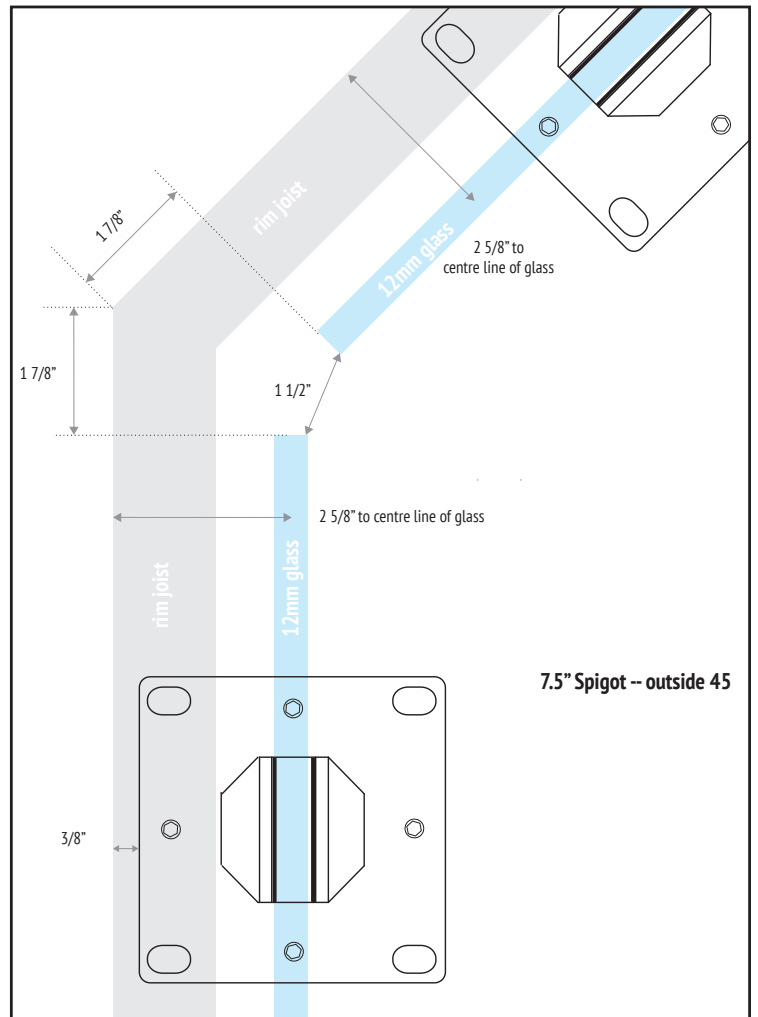
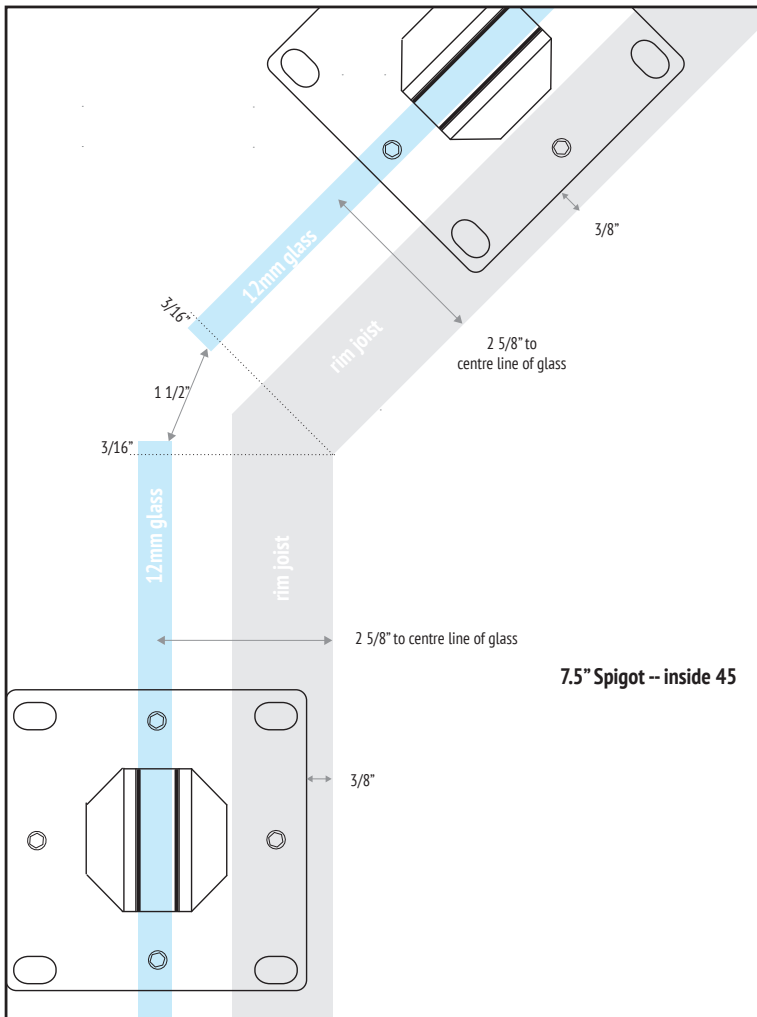
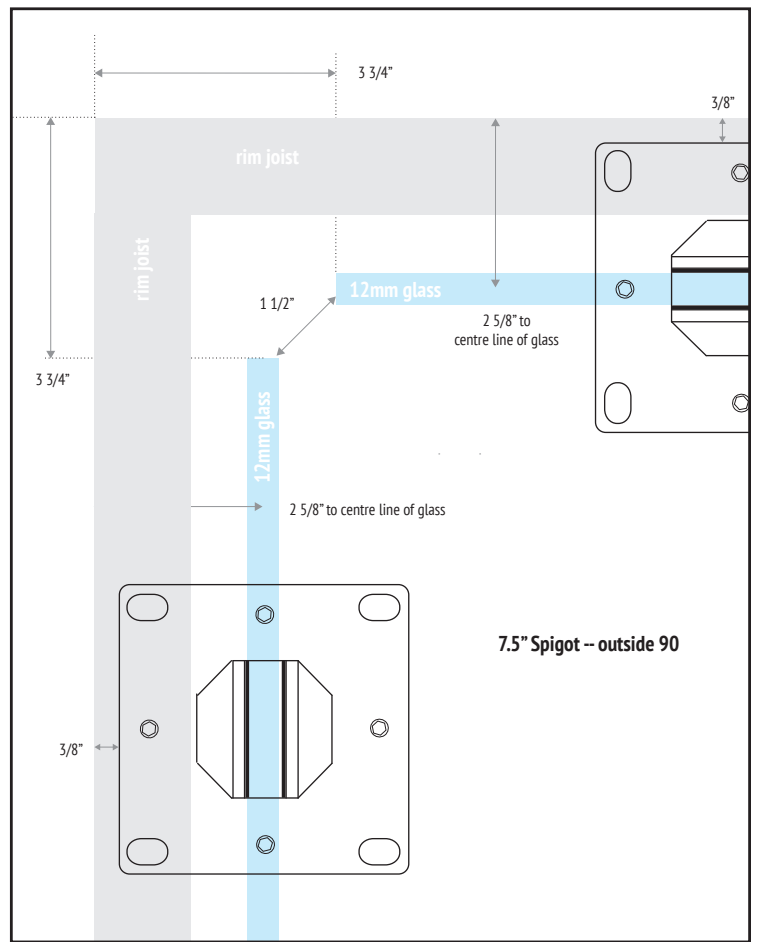
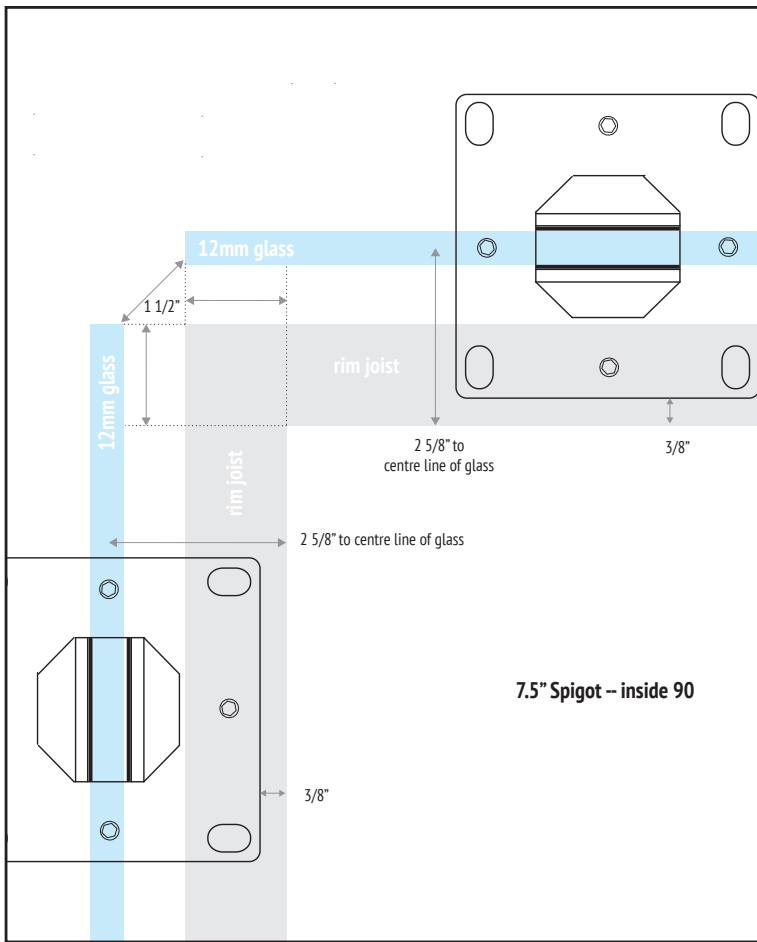

GLASS WIDTH	SPIGOT CENTRE	
	IN FROM EACH END	SPIGOT O/C
"W"	"A"	"B"
66	6	54
64	6	52
62	6	50
60	6	48
58	6	46
56	6	44
54	6	42
52	6	40
50	6	38
48	6	36
46	6	34
44	6	32
42	6	30
40	6	28
38	6	26
36	6	24
34	5	24
32	5	22
30	5	20
28	5	18
26	5	16
24	5	14
22	4	14
20	4	12
18	4	10
16	3	10
14	3	8
12	3	6
10	2.5	5
9.375	2.3125	4.75
6.75	1	4.75

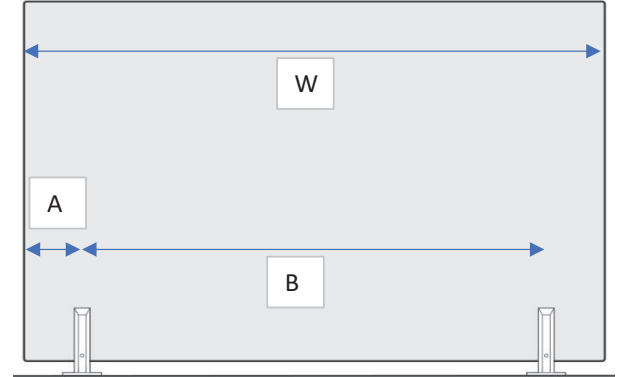

OUTSIDE EDGES OF GLASS LINED UP WITH OUTSIDE OF SPIGOT BASES
 OUTSIDE EDGES OF GLASS LINED UP WITH OUTSIDE OF SPIGOT UPRIGHTS

ALL PANELS TO BE 12MM TEMPERED AND HEAT SOAKED GLASS IN ACCORDANCE WITH CAN/CGSB-12.1-M.



Any installation or use of the product must be in accordance with all local zoning and/or building codes. The consumer assumes all risk and liability associated with the installation or use of this product. Check with local municipalities for building code requirement in your area before installing.

FOLLOW • LEARN • LIKE

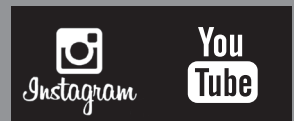

www.invisirail.com

sales@invisirail.com

Toll free 1-888-681-9733